



Utilizing Hollow Screw Processors for Cooling Ash in Fluidized Bed Combustion Technologies.

Fluidized bed Combustion (FBC) is a method of burning fuel, which is continually fed into a bed of inert material such as sand, silica, alumina or ash and/ or limestone. These materials are kept suspended through the action of the primary air distributor below the combustion floor. The furnace chamber floor is slotted, perforated or fitted with nozzles to uniformly distribute the up flowing air. Turbulence in the chamber is induced by the fluidization of the particles at the airflow rate required for combustion. Improved mixing generates heat at a substantially lower and more uniformly distributed temperature.

When fluidization takes place, the bed of material exhibits the properties of a liquid. As the air velocity increases, added turbulence is achieved and offers several advantages, such as less volatilization of alkali compounds, fewer hot spots, and less sensitivity to the quantity and nature of ash in the fuel. As soon as the fuel ignition temperature is achieved, fuel can be fed into or over the bed to achieve the desired operating temperature.

Major categories of Fluidized Bed Boilers include Bubbling-Bed Units, Circulatory-Bed Units and Transport-Reactor Units.

The fundamental distinguishing feature of all FBC units is the velocity of air through the bed. Bubbling-Bed has lower fluidization velocities to prevent solids from carrying over, or elutriating from the bed into the convective passages. As the air passes through the bed, large particles fall back while the fine particles are either captured by the dust collectors or removed in a baghouse. Circulating-Bed Boilers require partial recirculation or reinjection of solids escaping the bed, to obtain satisfactory performance without substantially increases the size of the combustor. This is achieved by merely increasing and maintaining continuous high air velocities to lift the particles to the combustion chamber where they continue recirculate, thereby increasing the residence time and combustion efficiency avoiding many

problems associated with under-bed and over-bed feeding of the fuel.

FBC maybe classified as semi entrained or fully entrained reactors.

Ash Systems

A few areas of the boiler system require regular maintenance during scheduled outages to ensure high availability. The maintenance addresses wear caused by the erosive nature of the bed material mainly due to high ash fuel content.

Typical water cooled **Holo-Scru Coolers** provide proven reliability to drain and cool bed material from the FBC. A typical **Holo-Scru Cooler** design is shown in Fig. 1. Hot ashes and some inert material such as sand discharges at the bottom of and enter the screw cooler through the flooded inlet. The hot product is then continuously conveyed into the discharge at an angle and dumped into the ash handling system.

Cooling of ash commences as soon as it comes in contact with a water-cooled surface such as the screw and the housing. Substantial exchange of heat occurs between the hot product and the rotating screw and housing. Efficient cooling of product is accomplished by particle contact with the heat exchange surface, therefore, a relatively long total time of retention of the particle in contact with the rotor surfaces is required. Contact must be continuous and short duration, so that all particles may come in contact with the heat exchange surface area. The ideal condition would be for the product to be in a fluidized state and highly flowable.

Therma-Flite provides a wide range of models and types of **Holo-Scru Coolers** custom designed and built according to customer provided specifications.

Ash cooling screws are typically designed to handle boiler ash with a discharge temperature of up to 2000 F and cooling it down to 400 F or less so it can enter the ash handling system.

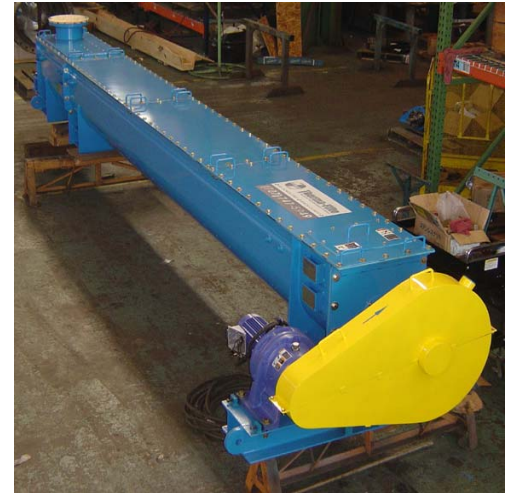
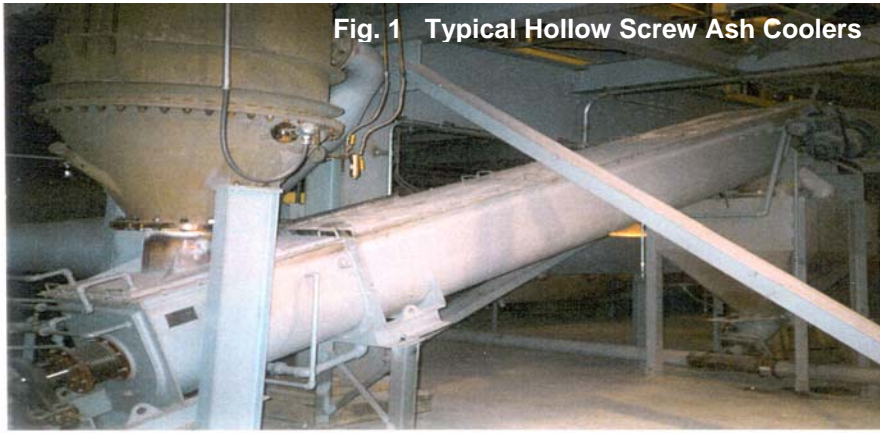

Typical screw design pressures vary from 75 psig to 250 psig while the jacketed U-trough housing runs usually from 15 to 50 psig. **Recent developments in the FBC design require a product chamber pressure 300 psig or higher. Therma-Flite has provided FBC manufacturers with jacketed tubular housing equipped with patented Shaft Rider Seals to contain product chamber pressures of 300 psig or higher.**

Flight Single Pad as opposed to Twin Pad Design

Most processors are built with single pad construction as opposed to a Twin Pad design. Although both constructions are employed to overcome the thermal stresses brought about by the expansion of the screws at elevated temperature.

Recent Developments

Perhaps the area of most concern when operating with Ash Screw Coolers is erosion of screw flights and housing interior liners. Many boilers experience unscheduled shutdowns because of wear problems particularly at the inlet zone where the screw flights find itself underneath a column of abrasive material constantly bearing down on the screws.

A new design replacing the hollow flights at the inlet section with solid stainless steel flights with hardface overlay extends the life by three or four times.

By adding rifle bars at the interior lining of the housing minimizes wear as well.

The advantages of Single Pad over the Twin Pad Design

1. The structure of the Twin Pad design is flexible and can move in all directions, which induces unwanted stresses on the welds joining the flights. While the single pad design allows the flights to move as a single unit thereby eliminating unnecessary stresses.
2. The twin pad design has no control in preventing the heat transfer media from migrating between flights. The pressure inside the screw pushes the fluid underneath the pad allowing the fluid to transfer between flights.
3. The twin pad construction covers the entire stem pipe (screw Shaft), making the walls unnecessarily thick and thereby reducing the heat transfer capability of the unit.

Summary

Since nearly any combustible products, including such difficult fuels as oil shales, anthracite wastes, and residual oils, can be effectively burned, Fluidized Bed Combustion has gained worldwide commercial status. Environmentally, its competitiveness with flue gas desulfurization, coal cleaning and advanced technologies such as liquefaction has been established. Besides the front-end technologies of fuel preparation and handling, processing equipment and combustion design, recent improvements in the ash handling technology should also be considered.

Partial Recent User's List

<u>Customer</u>	<u>Product Description</u>	<u>Model No.</u>
ABT (UK) Ltd.	Ash Coolers	24-20-5, Style B
Air Products	Ash Coolers	12-16-4, Style B
Arizona Public Services	Lime Coolers	18-20-4, Style B
Alstom Power (ABB)	Ash Coolers	24-20-6, Style B
Babcock and Wilcox	Ash Coolers	24-20-5, Style B
Beaumont Birch Co.	Ash Coolers	24-10-5, Style B
Berlie Technologies	Ash Coolers	24-20-5, Style B
Coal Technology Corp.	Char Coolers	36-10-6, Style B
City of Los Angeles	Ash Coolers	9-15-3, Style B
Denver Equipment	Ash Coolers	7-10-2, Style B
Foster Wheeler USA Corp.	Ash Coolers	18-20-4, Style B
GDC Engineering	Ash Coolers	12-20-3, Style B
GWF Power Systems	Ash Coolers	12-16-5, Style B
Heyl and Patterson	Ash Coolers	9-10-3, Style B
Kellogg Co.	Pressurized Ash Coolers	36-20-6, Style B
Pyropower	Ash Coolers	12-15-3, Style B
Reilly Industries	Ash Coolers	20-20-4, Style B
Ridge International	Ash Coolers	12-15-3, Style B
Rollins Environmental	Ash Coolers	18-22-4, Style B
RUST Environmental	Ash Coolers	24-20-5, Style
Separation and Recovery Systems	Ash Coolers	12-20-2, Style A
Southern Company Services, Inc.	Pressurized Ash Coolers	12-16-3, Style B
Tampella Power Co.	Ash Coolers	24-20-5, Style B
Westinghouse	Ash Coolers	18-18-4, Style B



Overcoming the problems associated with Hollow Screw Processors for Cooling Ash in Fluidized Bed Combustion Technologies.

-Solid Stainless Steel Helicoid Flight construction at the inlet section of the screw rotor.

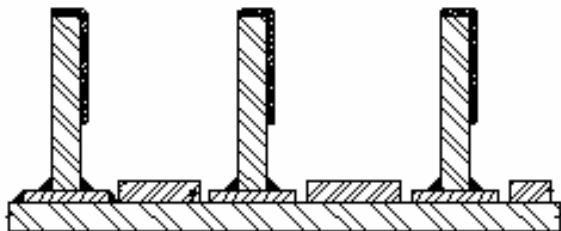

SOLID FLIGHT SECTION

- ◆ Stainless Steel can withstand the high temperatures in the inlet section of the cooler.
- ◆ Reduces potential leaks in the inlet section of the screw rotor due to thermal stress and deformation.
- ◆ Increases the life of the screw rotor.
- ◆ Decreases maintenance cost and weld repair.
- ◆ Hardface overlay procedures are utilized to increase the wear resistance of the flights.

-A Hollow Flight construction is utilized on the remainder of the rotor.

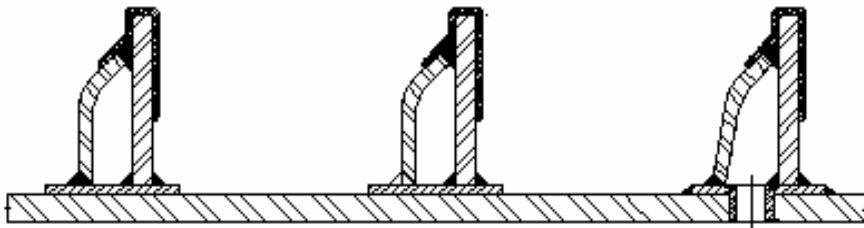

HOLLOW FLIGHT SECTION

- ◆ Hollow flights allow the cooling medium to flow through the flights for increased heat transfer surface area.
- ◆ Single pad design allows expansion and contraction while minimizing stress in the weld joints.
- ◆ Hardface overlay procedures are utilized to increase the wear resistance of the flights.

-Jacketed Housings Cross-Sections.

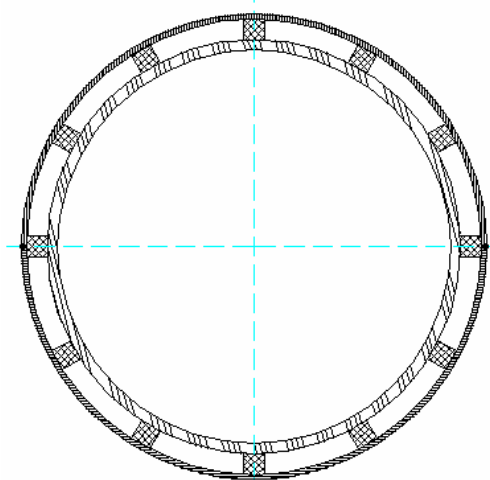
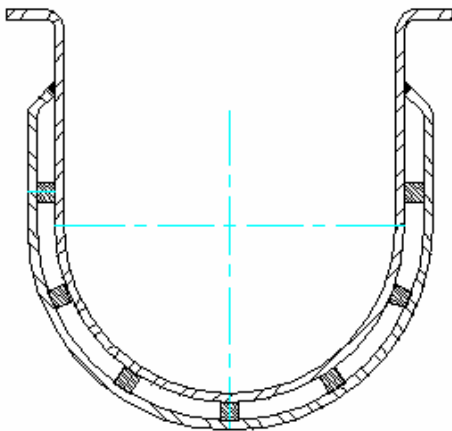

- ◆ Jacketed housing increases the cooling capability of the processor.
- ◆ Increases the life expectancy of the housing by keeping the carbon steel in operational temperature limits.

The successful operation of a Hollow Screw Processor for cooling ash in Fluidized Bed Combustion Technologies is dependant upon the ability to overcome the extreme environment at the inlet section of the screw rotor.

Secondary in the design, you must consider the heat transfer capabilities of the processor as a time dependant variable and all factors must be taken in consideration. These factors vary from heat transfer surface area requirements, performance per square foot of area, fouling of the rotor due to ash buildup and fouling of internal heat transfer area due to scale and oxidation.



Therma-Flite
The Screw Heat Exchanger Company

P.O. Box 847
849 Jackson St.
Benicia, CA 94510
Ph (707) 747-5949
Fx (707) 747-5951
www.therma-flite.com